

# ADH.7... 4/3 AND 4/2 PILOTED VALVES CETOP 7/NG16

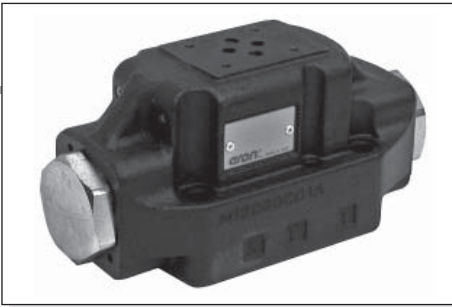

ADH.7...	
STANDARD SPOOLS FOR ADH.7	CH. I PAGE 54
TECH. SPECIFICATIONS ADH.7...	CH. I PAGE 55
SUBPLATES BSH.7...	CH. I PAGE 56/57
CETOP 3/NG06	CH. I PAGE 8
STANDARD SPOOLS FOR AD.3.E	CH. I PAGE 10
AD.3.E...	CH. I PAGE 11
ADC.3...	CH. I PAGE 5
"A09" DC COILS	CH. I PAGE 7
"D15" DC COILS	CH. I PAGE 19
"B14" AC SOLENOIDS	CH. I PAGE 19
STANDARD CONNECTORS	CH. I PAGE 20

### ORDERING CODE

<b>ADH</b>	Piloted valve - <b>Pilot valves and any modulating valves should be ordered separately</b>
<b>7</b>	CETOP 7/NG16
<b>*</b>	Mounting type (see next page)
<b>**</b>	Spool type (see next page)
<b>*</b>	Piloting and draining <b>I</b> = X internal / Y internal <b>IE</b> = X internal / Y external <b>EI</b> = X external / Y internal <b>E</b> = X external / Y external (see Tab.1 at side)
<b>R</b>	Check valve incorporated at port P (Tab. 2) Only for <b>I</b> and <b>IE</b> versions (omit if not required)
<b>**</b>	<b>00</b> = No variant <b>LC</b> = Main spool stroke limiter
<b>2</b>	Serial No.

**TAB. 2 - INTERNAL CHECK ON P  
ADH7\*.\*\*.R.\*\*.2 VERSION**

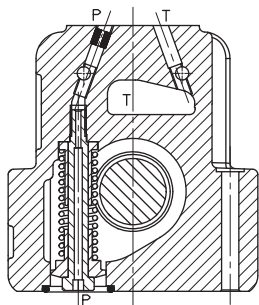

• For the spools 02-04-14-28 the piloting is normally external; the internal piloting is possible only with the internal check valve (R).

Type ADH.7 distributors are intended for interrupting, inserting and diverting a hydraulic system flow. Normally these distributors are composed of a main stage, crossed by the circuit main flow, and of a pilot stage available in several versions.

Various types of controls are available, used either individually or in combination for, among other functions, stroke limitation and main spool movement speed control, in order to optimize the hydraulic system operation where this type of valve is employed.

In those cases where normally to drain spools are used, it is necessary to remember that the minimum changeover pressure due to the opposing springs is equal to approximately 5 bar (see the operating features table next pages) and it is consequently necessary to specify when ordering the check valve incorporated in the P line, if required (as shown below).

- Mounting surface in accordance with UNI ISO 4401 - 07 - 06 - 0 - 94 standard (ex CETOP R 35 H 4.2-4-07).
- Pilot operated spool, solenoid controller.
- Stroke control of main spool.
- Presetting for pressure reducing valve mounting.
- Presetting for single-acting throttle valve mounting.

**TAB. 1 - PLUGS ARRANGEMENT FOR THE PILOT AND DRAIN LINES**

Plugs type used: M5x5 both for pilot and drain.

Note: standard M6x6 orifice Ø1,5 insert in the P port (Z)

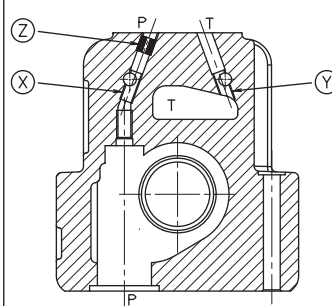

**ADH.7...I**

X internal piloting  
Y internal draining

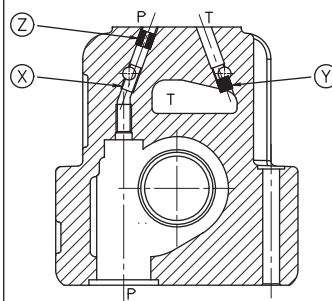
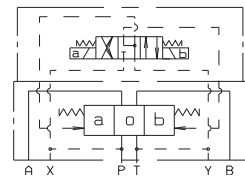

**ADH.7...IE**

X internal piloting  
Y external draining

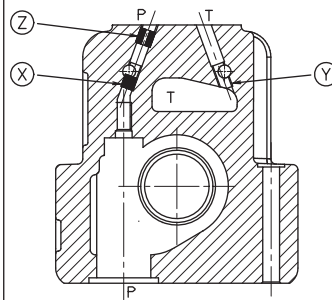
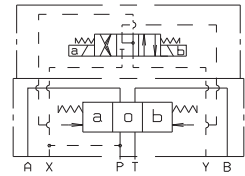

**ADH.7...EI**

X external piloting  
Y internal draining

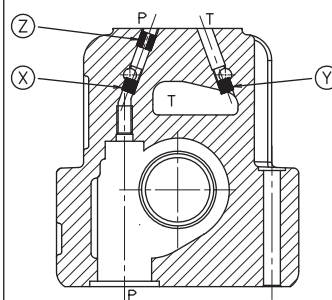
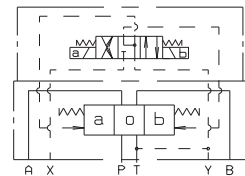

**ADH.7...E**

X external piloting  
Y external draining

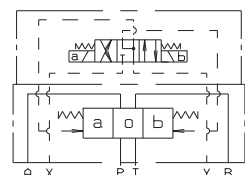

**PRESSURE DROPS**

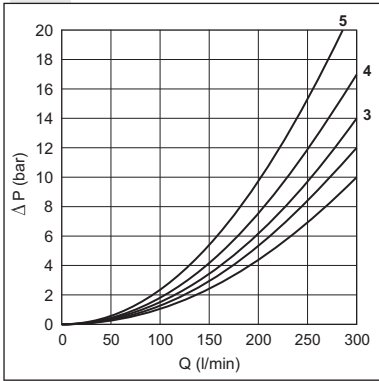

The two diagrams show the "Pressure drops" in relation to spools adopted for normal usage (see table). The fluid used was a mineral based oil with a viscosity of 46 mm<sup>2</sup>/s at 40° C.

**PRESSURE DROPS FOR INTERNAL CHECK ON P VERSION**

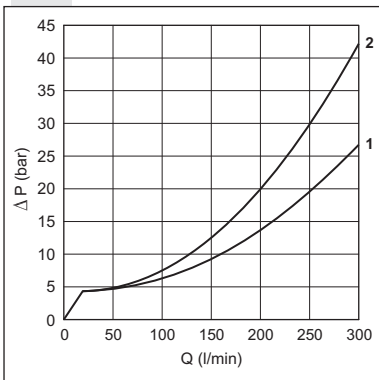

Spool type	Connections		
	P→A	P→B	P→T
02	1	1	1
04	1	1	2

Curve No.

The limit of use test has been carried out with external draining and orifice Ø1,5 insert in the P port (Z). The fluid used was a mineral based oil with a viscosity of 46 mm<sup>2</sup>/s at 40° C.

(\*) For the "E mounting" the locating spring works only with the steady system (\* Spools with price increasing)

Spool type	Connections				
	P→A	P→B	A→T	B→T	P→T
01	ENERGIZING DE-ENERGIZ.	2	1	3	3
02	ENERGIZING DE-ENERGIZ.	1	1	3	3
03	ENERGIZING DE-ENERGIZ.	2	1	3	3
04	ENERGIZING DE-ENERGIZ.	2	2	4	4
05	ENERGIZING DE-ENERGIZ.	1	1	2	2
66	ENERGIZING DE-ENERGIZ.	1	1	2	3
10	ENERGIZING DE-ENERGIZ.	2	1	3	3
14	ENERGIZING DE-ENERGIZ.	1	1	3	3
28	ENERGIZING DE-ENERGIZ.	1	1	3	3
23	ENERGIZING DE-ENERGIZ.	2	1	3	3

Curve No.

**LIMIT OF USE**

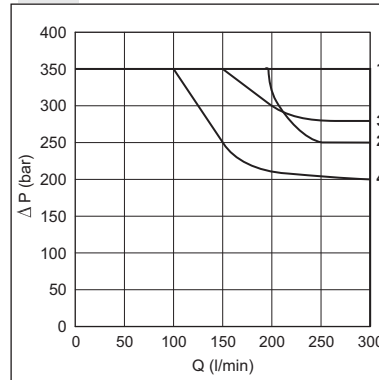

Spool type	No. Curve
01	1
02	2
03	1
04	3
05	1
66	1
10	1
14	4
28	4
23	1

**SPOOLS AND MOUNTING TYPE**

	C mounting	A mounting	B mounting	E mounting (*)	P mounting
<b>Pilot Piloted</b>	AD.3.E.03.C... ADH.7.C...	AD.3.E.03.E... ADH.7.A...	AD.3.E.03.F... ADH.7.B...	AD.3.E.16.E... ADH.7.E...	AD3E16E/AD3E16F ADH.7.P...
<b>Scheme</b>					
<b>Spool type</b>					
01					
02					
03					
04*					
05					
66					
10*					
14*					
28*					
23*					

## PILOT SOLENOID CONTROL VALVE SPECIFICATIONS

FOR DIFFERENT CONTROLS, PLEASE CONTACT OUR TECHNICAL ARON SERVICE

Max. operating pressure ports P/A/B	350 bar
Max. operating pressure port T (int. drainage)	160 bar
Max. operating pressure port T (ext. drainage)	250 bar
Max. piloting pressure	210 bar
Min. piloting pressure*	12 bar
Max flow	300 l/min.
Piloting oil volume for engagement 3 position valves	4 cm <sup>3</sup>
Piloting oil volume for engagement 2 position valves	8 cm <sup>3</sup>
Hydraulic fluid	mineral oil DIN 51524
Fluid viscosity	2.8 ÷ 380 mm <sup>2</sup> /s
Fluid temperature	-20°C ÷ 70°C
Ambient temperature	-20°C ÷ 50°C
Max. contamination level	class 10 in accordance with NAS 1638 with filter $\beta_{25} \geq 75$
Weight ADH7 without pilot valve	7 Kg
Weight ADH7 with pilot valve with 1 AC solenoid	8,2 Kg
Weight ADH7 with pilot valve with 1 DC solenoid	8,4 Kg
Weight ADH7 with pilot valve with 2 AC solenoids	8,5 Kg
Weight ADH7 with pilot valve with 2 DC solenoids	9 Kg

\* For valves with internal drain (Y), tank pressure on T must be added to min. piloting pressure.

For version "R" with check valve on P, the cracking pressure of 5 bar is obtained with flow rate > 25 l/min.

### Switching time

Such values refer to a tests carried out with Aron solenoid valve type AD3E03 with P = 100 bar pressure and Q = 100 l/min flow. Orifice  $\phi$ 1.5 mm, insert on piloting port, using a mineral oil at 40°C. with 46 mm<sup>2</sup>/s viscosity.

### TEMPI DI RISPOSTA VALVOLA PILOTATA

Solenoids	ENERGIZING $\pm 10\%$ (ms)		DE-ENERGIZING $\pm 10\%$ (ms)			
	01 - 03		01 - 03			
No. Spool	01 - 03		01 - 03			
Scheme	2 positions	3 positions	2 positions	3 positions		
<b>AC</b>	50	20	25	30		
<b>DC</b>	70	35	40	50		
Solenoids	02		04		02 - 04	
	02 - 04		02 - 04		02 - 04	
No. Spool	02		04		02 - 04	
Scheme	2 posit.	2 posit.	3 posit.	2 positions	3 positions	
<b>AC</b>	35	60	30	25	25	
<b>DC</b>	55	80	40	40	50	

**Note:** the solenoid valve type **ADC.3.E...** (with A09 coil) and **AD3.E...** (with D15 or B14 coils) could be used both as pilote valve, without any changement of technical features.

DC 229.5 AC 201  
DC 155 AC 135

1  
2  
3  
4  
5

SE  $\phi$  3     $\phi$  6.5     $\phi$  11

205

51.7    101.6    51.7

9.4    46    69.8

### CETOP 7 MOUNTING SURFACE

71.5  
69.9  
55.6  
14.3  
1.6  
M10-6H  
M6x1.2  
T    P    X  
A    B    Y  
18.3  
34.1  
50  
65.9  
76.6  
88.1  
101.6  
12.7  
5.4

- Piloted valve fixing:  
n° 4 screws T.C.E.I. M10x60 - Tightening torque 40 Nm  
n° 2 screws T.C.E.I. M6x55 - Tightening torque 8 Nm
- Seals:  
n° 4 OR 2-118 PARKER (type 130)  
n° 2 OR 2-013 PARKER (type 2043)

### SPOOL STROKE ADJUSTMENT

CH 19  
CH 10  
66.5

1 Piloted solenoid valve type **AD3E...** or **ADC.3.E...** CETOP 3/NG6  
 2 Calibrated diaphragms **AD3E...**  
 3 Flow regulation valve type **AM3QF..C**  
 4 Pressure reduction valve type **AM3RD..C**  
 5 Main valve type **ADH7..E**

**1**

**BSH.7.12 WITH P, T, AND A, B REAR 3/4" BSP**

- BSH** Single plate for piloted valve
- 7** CETOP 7/NG16
- 12** 3/4" BSP rear connectors
- 00** No variant
- 1** Serial No.

Weight: 5,5 Kg

Fixing screws M8x55 UNI 5931

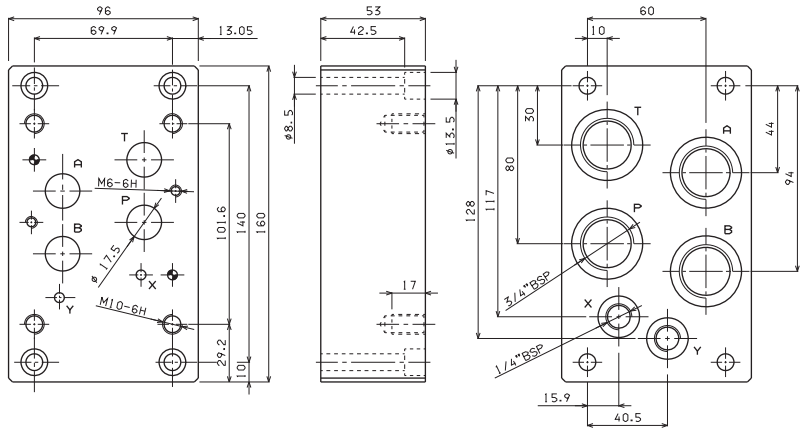

**BSH.7.13 WITH P, T AND A, B REAR 1" BSP**

- BSH** Single plate for piloted valve
- 7** CETOP 7/NG16
- 13** 1" BSP rear connectors
- 00** No variant
- 1** Serial No.

Weight: 4,7 Kg

Fixing screws M8x55 UNI 5931

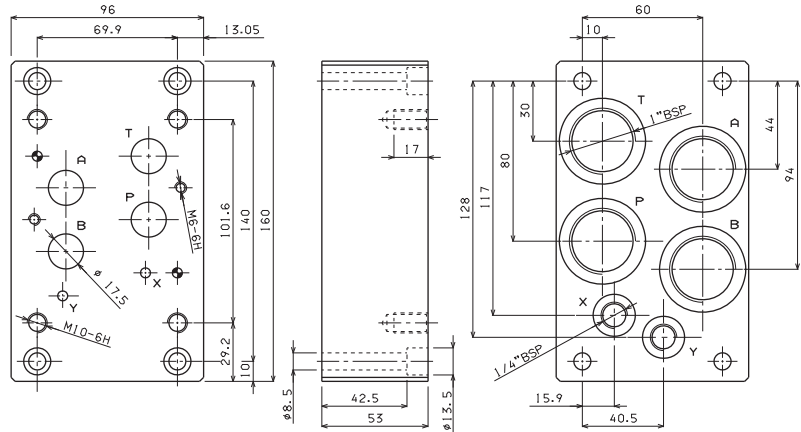

**BSH.7.14 WITH P, T AND A, B SIDE 3/4" BSP**

- BSH** Single plate for piloted valve
- 7** CETOP 7/NG16
- 14** 3/4" BSP side connectors
- 00** No variant
- 1** Serial No.

Weight: 6,3 Kg

Fixing screws M8x55 UNI 5931

